

Products

2024

EIKUND

# Content

## About Eikund

Eikund was established the spring of 2016, and since then we have managed to gather the best of Norwegian furniture design from the 1950s and 60s under one brand.

This is a result of a treasure hunt that gives old icons from the Norwegian design legacy new life. Our collection of Norwegian mid-century design features iconic works by renowned masters such as Fredrik A. Kayser, Torbjørn Afdal, Sigurd Resell, Sven Ivar Dysthe, Torbjørn Bekken and Arne Tjømsland.

Quality requirements for high-end furniture makes us both sustainable and viable; we would rather produce furniture designed to last, rather than something short lived and part of a planned obsolescence society. Every single product from us is Nordic modernism at its best!

At Eikund, we have high ambitions. To ensure that we deliver only the best products and the best customer service, high quality is our core value, and it underlies everything we do. As a company, we want our actions to have as little impact on the environment as possible. This is well illustrated in our design and material use.

# Content

Standard	Dining chairs	Hertug dining chair	Fredrik A. Kayser	4
		Ry dining chair	Sven I. Dysthe	6
	Arm chairs	Ry arm chair	Sven I. Dysthe	8
		Veng arm chair	Torbjørn Bekken	10
	Lounge chairs	Veng lounge chair	Torbjørn Bekken	12
		Broadway lounge chair	Torbjørn Afdal	14
		Kryset lounge chair	Fredrik A. Kayser	16
		Hunter lounge chair	Torbjørn Afdal	18
		Fluffy lounge chair	Fredrik A. Kayser	20
		UnFluffy lounge chair	Fredrik A. Kayser	22
	Coffee tables	Evja coffee tables	Torbjørn Bekken	24
	Dining tables	Oma dining table - extendable	Sigurd Resell	28
		Øya dining table	Sigurd Resell	21
	Project	Bar stool	Jaer bar stool	Sigurd Resell
Dining chair		Era dining chair	Sven I. Dysthe	37
Dining table		Oma dining table - static	Sigurd Resell	39
General	Materials	Hardwood, Fenix & MDF		42
		Textiles from Kvadrat		43
		Semi-aniline leather from Sørensen		44
		Aniline leather from Tärnsjö and Stolz		44
		Rope from Liros		45
		Sheepskin from the Faroe islands		45





Dining chair

Hertug









# Hertug





## HARDWOOD

	White oiled oak
	Oiled oak
	Smoke stained lacq. oak
	Oiled walnut







## SEMI-ANILINE LEATHER RANGE: SPECTRUM

	Ginger
	Tan
	Havanna
	Ruby
	Moss
	Black

## ANILINE LEATHER RANGE: SOFT

	Natural
	Cognac
	Brown
	Black

## TEXTILE GROUP 1

	Blackenedblue
	Darkgrey
	Lightgrey
	Apricot
	Burgundy
	Slate

## TEXTILE GROUP 2

	Blackenedwhite
	Darkolive
	White

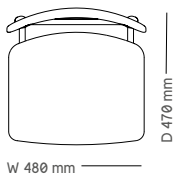
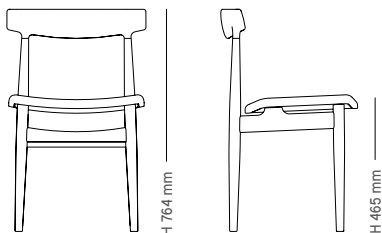

Hertug is an elegant dining chair recognisable by the lines between the backlegs and backrest. It was originally drawn for Viken Møbelfabrikk in Bergen by Fredrik A. Kayser while he was a freelance designer. Kayser graduated from National Academy of Craft and Art Industry in 1945. He designed Hertug with a simple and organic form to make it fit into all kinds of interiors. The seat has a light and floating effect created by only touching the frame where necessary, while the backrest makes you see and feel true craftsmanship.

Designed in 1959



# Dining chair

# RY









# Ry





## HARDWOOD

	White oiled oak
	Oiled oak
	Smoke stained lacq. oak







## SEMI-ANILINE LEATHER RANGE: SPECTRUM

	Ginger
	Tan
	Havanna
	Ruby
	Moss
	Black

## ANILINE LEATHER RANGE: SOFT

	Natural
	Cognac
	Brown
	Black

## TEXTILE GROUP 1

	Blackenedblue
	Darkgrey
	Lightgrey
	Apricot
	Burgundy
	Slate

## TEXTILE GROUP 2

	Blackenedwhite
	Darkolive
	White

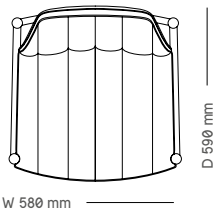
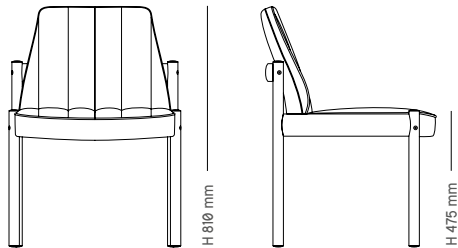

W 580 mm

Ry has solid wood as the main material, so that the true craftsmanship in this product can be showcased at its best. Sven Ivar Dysthe graduated from the Royal College of Art in 1954. He designed Ry in a way that make it efficient for production. The dining chair and armchair can be manufactured with many of the same parts where only minor changes and additions, such as the armrests, are needed. There are many details to both versions of the chair, but the main attraction is probably the connection between the backrest and the horizontal leg stretcher, this subtle detail exemplifies the brilliance of Dysthe's design. The overall style of the chair, with voluminous upholstery and great comfort makes this chair a true 1960s classic. Now it's finally back in production!

Designed in 1961

Arm chair



RY











# Ry





## HARDWOOD

	White oiled oak
	Oiled oak
	Smoke stained lacq. oak







## SEMI-ANILINE LEATHER RANGE: SPECTRUM

	Ginger
	Tan
	Havanna
	Ruby
	Moss
	Black

## ANILINE LEATHER RANGE: SOFT

	Natural
	Cognac
	Brown
	Black

## TEXTILE GROUP 1

	Blackenedblue
	Darkgrey
	Lightgrey
	Apricot
	Burgundy
	Slate

## TEXTILE GROUP 2

	Blackenedwhite
	Darkolive
	White

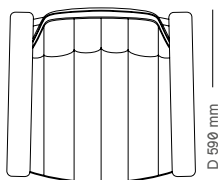
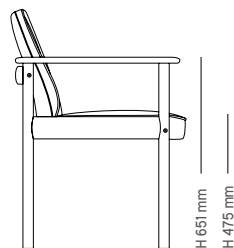
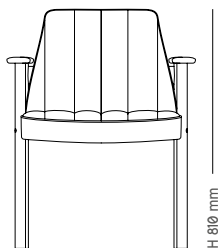

W 630 mm

Ry has solid wood as the main material, so that the true craftsmanship in this product can be showcased at its best. Sven Ivar Dysthe graduated from the Royal College of Art in 1954. He designed Ry in a way that make it efficient for production. The dining chair and armchair can be manufactured with many of the same parts where only minor changes and additions, such as the armrests, are needed. There are many details to both versions of the chair, but the main attraction is probably the connection between the backrest and the horizontal leg stretcher, this subtle detail exemplifies the brilliance of Dysthe's design. The overall style of the chair, with voluminous upholstery and great comfort makes this chair a true 1960s classic. Now it's finally back in production!

Designed in 1961





Arm chair

Veng









# Veng





## HARDWOOD

-  White oiled oak
-  Oiled oak
-  Smoke stained lacq. oak
-  Oiled walnut







## SEMI-ANILINE LEATHER RANGE: SPECTRUM

-  Ginger
-  Tan
-  Havanna
-  Ruby
-  Moss
-  Black

## ANILINE LEATHER RANGE: SOFT

-  Natural
-  Cognac
-  Brown
-  Black

## TEXTILE GROUP 1

-  Blackenedblue
-  Darkgrey
-  Lightgrey
-  Apricot
-  Burgundy
-  Slate

## TEXTILE GROUP 2

-  Blackenedwhite
-  Darkolive
-  White

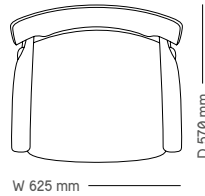
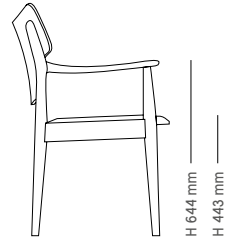
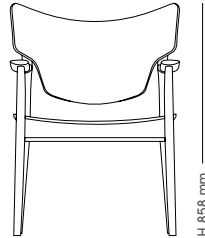

Veng arm chair has a strong personality and is one of the most expressive chairs Torbjørn Bekken designed. Bekken graduated from the National Academy of Craft and Art Industry in 1946. He designed the chair while working for the innovative interior design company Rastad & Relling Tegnekontor. With the stunning sculptural and chief-looking appearance the forgotten Norwegian icon is finally coming back to life.

Designed in 1960.

Lounge chair

Veng



# Veng

## HARDWOOD

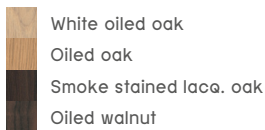

## SEMI-ANILINE LEATHER RANGE: SPECTRUM

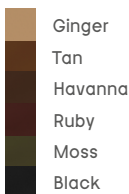

## ANILINE LEATHER RANGE: SOFT

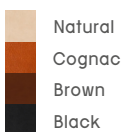

## TEXTILE GROUP 1

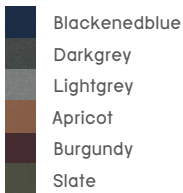

## TEXTILE GROUP 2

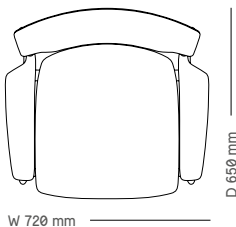
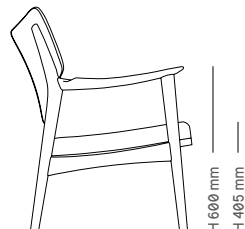
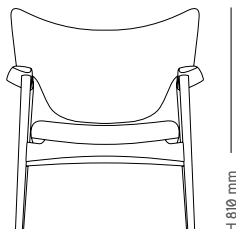

Veng lounge chair is one of the most dramatic chairs Torbjørn Bekken designed. Bekken graduated from the National Academy of Craft and Art Industry in 1946. He designed the chair while working for the innovative interior design company Rastad & Relling Tegnekontor. It has an intriguing dynamic between the slender, curved backrest and the highly sculptural armrests. The Veng lounge chair is both elegant and bold at the same time.

Designed in 1960.



Lounge chair

# Broadway









# Broadway





## HARDWOOD

-  White oiled oak
-  Oiled oak
-  Smoke stained lacq. oak

## SEMI-ANILINE LEATHER RANGE: SPECTRUM

-  Ginger
-  Tan
-  Havanna
-  Ruby
-  Moss
-  Black

## ANILINE LEATHER RANGE: SOFT

-  Natural
-  Cognac
-  Brown
-  Black

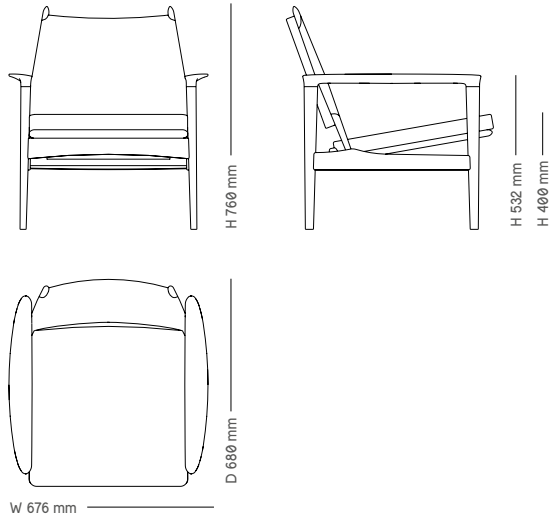

With its turned siderails pointing upwards as horns the lounge chair Broadway makes a strong statement. This is a chair that won Torbjørn Afdal a gold medal at the craftsmanship fair “So Wohnt Europa” in Munich in 1959. Afdal graduated from the Norwegian National Academy of Craft and Art Industry in 1946 and worked his whole career for the legendary Tegnekontoret Bruksbo. He designed the chair with extreme attention to detail: the shape and transition between legs and armrest is beyond words.

Designed in 1958

Lounge chair





# Krysset







# Krysset







## HARDWOOD

-  White oiled oak
-  Oiled oak
-  Smoke stained lacq. oak
-  Oiled walnut

## CUSHION & BACKREST RANGE: SOFT & SADDLE

-  Natural
-  Brown
-  Black

## CUSHION RANGE: TEXTILE GROUP 1

-  Blackenedblue
-  Darkgrey
-  Lightgrey
-  Apricot
-  Burgundy
-  Slate

## TEXTILE GROUP 2

-  Blackenedwhite
-  Darkolive
-  White

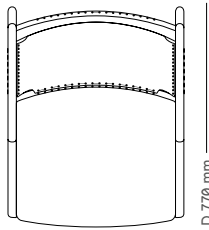
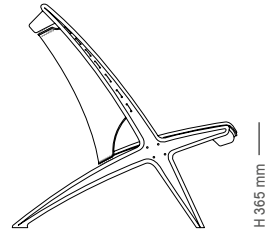
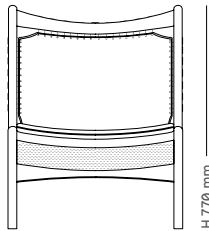

W 600 mm

Krysset is a Norwegian design icon with a distinguished cross-legged expression. Fredrik A. Kayser graduated from National Academy of Craft and Art Industry in 1945. He designed Krysset while being employed at Rastad & Relling Tegnekontor between 1952-56. The crossed legs shape the overall structure of the chair with darker wooden nails in the joints enhancing the crafted beauty. The backrest is stretched out like a sail by a piece of leather sewn to the frame.

Designed in 1955.





Lounge chair

# Hunter





# Hunter

## HARDWOOD

-  White oiled oak
-  Oiled oak
-  Smoke stained lacq. oak
-  Oiled walnut

## ANILINE LEATHER RANGE: SADDLE

-  Natural
-  Cognac
-  Black

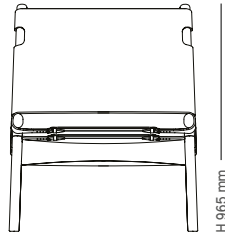

H 965 mm

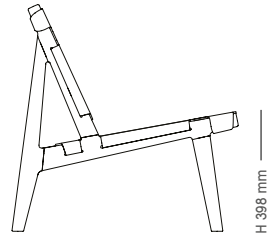

H 398 mm

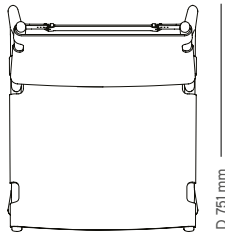

W 627 mm

D 751 mm

The way that the saddle leather is stretched around the wooden frame with adjustable belts, makes this a perfect example of the category "hunting chairs". These lounge chairs were immensely popular in the 1950s-60s and have now defined themselves as modern-day classics. Afdal graduated from the Norwegian National Academy of Craft and Art Industry in 1946 and worked his whole career for the legendary Tegnekontoret Bruksbo. Afdal designed the frame with a minimalistic aesthetic focusing on a fluid and organic form in contrast to other hunting chairs. "Simplicity" is a good description of the Hunter composition. This can be seen in the double layered leather with its matching edge stitching, together with its solid cast brass buckles. The Hunter lounge chair is a highly detailed piece with craftsmanship to last for generations.

Designed in 1960



Lounge chair

# Fluffy





# Fluffy

## HARDWOOD

-  White oiled oak
-  Oiled oak
-  Smoke stained lacq. oak

## SHEEPSKIN RANGE: LONG

-  Natural white
-  Natural black

NB! Variations might occur with the long sheepskin: the natural white version can have some yellow colour in it, and the natural black version can have some brown colour in it.

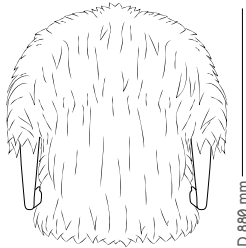
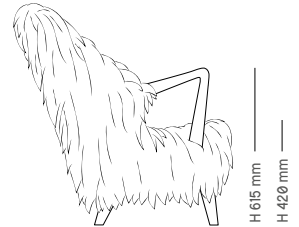
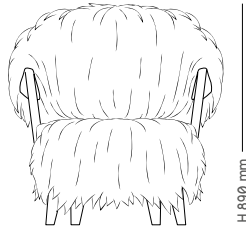

W 890 mm

The Fluffy lounge chair by Fredrik A. Kayser is characterized by its ultra-soft upholstery in Norwegian sheepskin, and its sloping armrests leaning you into a welcoming embrace. Kayser graduated from National Academy of Craft and Art Industry back in 1945 and the lounge chair was designed while being employed at Rastad & Relling Tegnekontor. It combines both art and function into one, a floating cloud of fluffiness that builds on the past for the present. This is a brand-new species that can live anywhere!

Designed in 1954



Lounge chair

# UnFluffy





# UnFluffy



## HARDWOOD

-  White oiled oak
-  Oiled oak
-  Smoke stained lacq. oak

## TEXTILE GROUP 3 ELLE

-  White
-  Beige
-  Brown

## TEXTILE GROUP 3 SAFIRE

-  Whitedots
-  Olivedots
-  Browndots

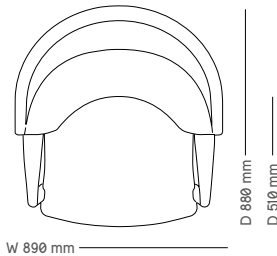
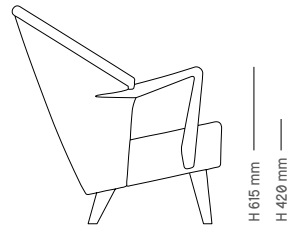
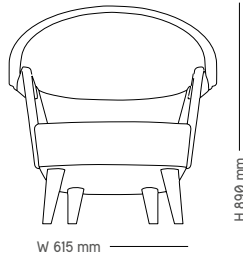

The UnFluffy lounge chair by Fredrik A. Kayser is characterized by its sloping armrests leaning you into a welcoming embrace. This is the more versatile sibling of the Fluffy lounge chair. Kayser graduated from National Academy of Craft and Art Industry back in 1945 and the lounge chair was designed while being employed at Rastad & Relling Tegnekontor. It combines both art and function into one, a floating cloud of fluffiness that builds on the past for the present. This is a brand-new species that can live anywhere!

Designed in 1954

Coffee table



Evja





# Evja

## HARDWOOD

-  White oiled oak
-  Oiled oak
-  Smoke stained lacq. oak

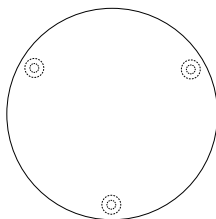
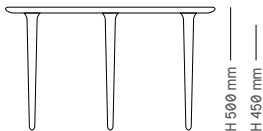

Ø 850 mm

Ø 700 mm

Evja is a family of lounge tables that Torbjørn Bekken designed with an organic and almost floating expression. Bekken graduated from the National Academy of Craft and Art Industry in 1946. Fresh from school he was picked up by the progressive furniture and interior design company Rastad & Relling Tegnekontor, where he worked for most of his career, and words best to describe him is technical, detail oriented and elegant. This can be exemplified by the long uninterrupted curving line from the edge of the table towards the legs, how it slightly narrowing downwards to the floor. It's like a ballerina lightly tipping around on the surface.

Designed in 1958.

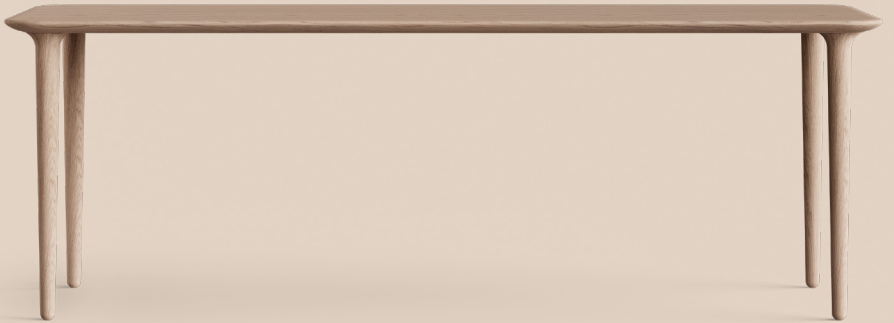

Coffee table

Evja



# Evja

## HARDWOOD

-  White oiled oak
-  Oiled oak
-  Smoke stained lacq. oak

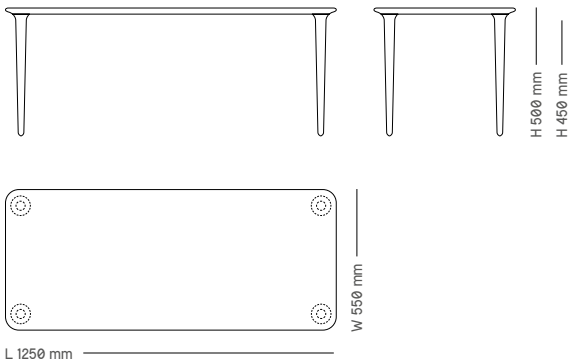

L 1250 mm

W 550 mm

H 500 mm

H 450 mm

Evja is a family of lounge tables that Torbjørn Bekken designed with an organic and almost floating expression. Bekken graduated from the National Academy of Craft and Art Industry in 1946. Fresh from school he was picked up by the progressive furniture and interior design company Rastad & Relling Tegnekontor, where he worked for most of his career. and words best to describe him is technical, detail oriented and elegant. This can be exemplified by the long uninterrupted curving line from the edge of the table towards the legs, how it slightly narrowing downwards to the floor. It's like a ballerina lightly tipping around on the surface.

Designed in 1958.

Dining table - extendable

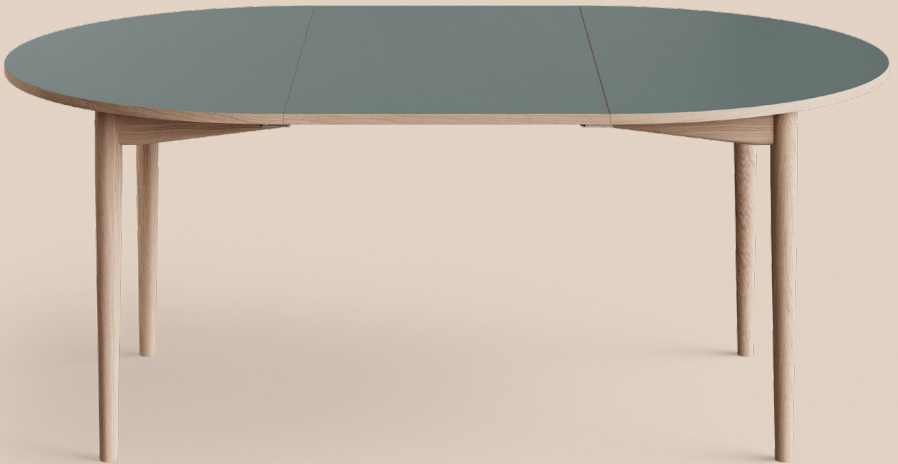

Oma





# Oma

Extendable

## HARDWOOD FRAME

-  White oiled oak
-  Oiled oak
-  Smoke stained lacq. oak

## TABLETOP &amp; LEAF

-  Beige Fenix
-  Teal Fenix
-  Black Fenix

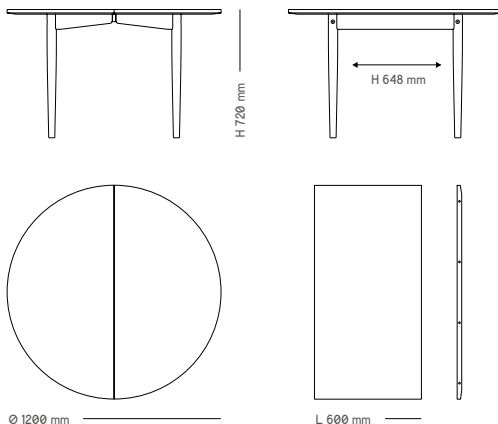

Oma is a dining table that has both a static version and an extendable version. The extendable version is designed to hold up to two leaves. There is no supporting leg needed for this solution.

Oma extendable is a part of a design series of dining tables designed in the mid 1950s. Sigurd Resell graduated from National Academy of Craft and Art Industry in 1947. He designed Oma while being employed at Rastad & Relling Tegnekontor in Oslo. What characterizes Resell's design is the defined logical construction where form follows function. The tabletop, which comes in solid wood or Fenix laminate, is perfectly balanced with its "sharp" form and modern aesthetics. The framework has a softer organic shape in solid wood, and as a complete product this translates into an instant classic. We are proud to have this beautiful product as part of the Eikund collection.

Designed in 1957.

# Oma

Extendable

## Seating arrangements

No leaves  
4 x Hertug

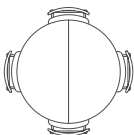

1 leaf  
6 x Hertug

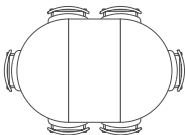

2 leaf  
8 x Hertug

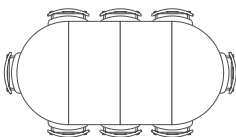

Dining table - extendable



Øya







# Øya

Extendable

## HARDWOOD FRAME

-  White oiled oak
-  Oiled oak
-  Smoke stained lacq. oak

## TABLETOP &amp; LEAF

-  White oiled oak
-  Oiled oak
-  Smoke stained lacq. oak
-  Black MDF/black Fenix

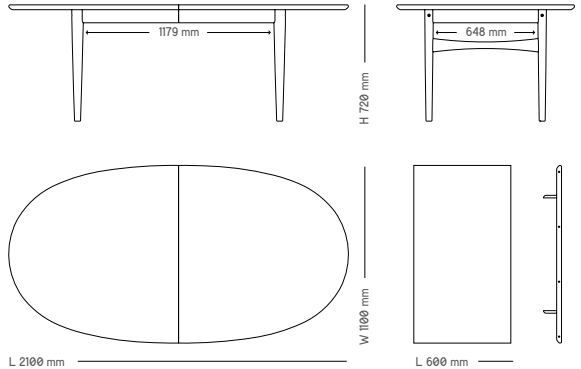

Øya dining table is designed to hold up to four leaves. The dining table comes with a centered-support leg. Please use the support leg from 2 leaves and up.

Øya is a extendable dining table that was only made for one client, a true "one of a kind" product. Sigurd Resell graduated from National Academy of Craft and Art Industry in 1947. He designed Øya while being employed at Rastad & Relling Tegnekontor in Oslo. What characterize Resell's design are the defined logical constructions where form is decided by function. The elegant elliptical shape of the tabletop is both classical and modern, with legs that strengthens this feeling with an oval to round shape. We are proud to have this unique and beautiful table as part of the Eikund collection.

Designed in 1956.



# Øya

Extendable

## Seating arrangements

No leaves  
6 x Hertug

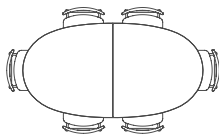

1 leaf  
8 x Hertug

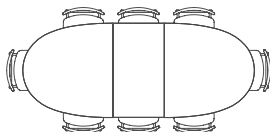

2 leaf  
10 x Hertug

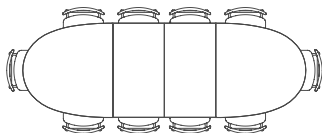

3 leaf  
12 x Hertug

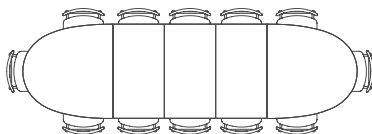

4 leaf  
14 x Hertug

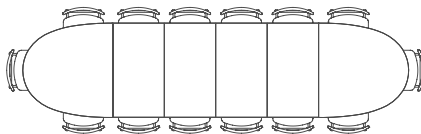

# Project

The products listed for projects are only meant for larger orders, that means a higher MOQ than our standard range. The numbers needed must be defined by request.

# 2024

Bar stool

Project

Jaer



EIKUND

[www.eikund.com](http://www.eikund.com)

# Jaer

## HARDWOOD



- White oiled oak
- White toned lacq. oak
- Oiled oak
- Clear lacq. oak
- Smoke stained lacq. oak
- Walnut stained oak
- Black lacq. oak

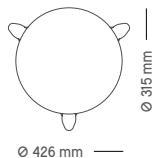
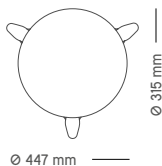
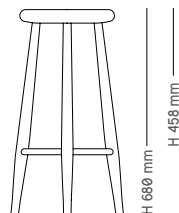
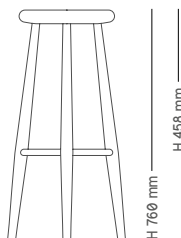

Jaer is a true mid-20th century design, but this is the first time it goes into serial production. The three-legged barstool definitely deserves more attention, it has a strong presence even though it has a humble and honest look. Sigurd Resell graduated from National Academy of Craft and Art Industry in 1947. He designed Jaer while working for the pioneering interior design company Rastad & Relling Tegnekontor in Oslo. The barstool is made from solid oak, and is available in a variety of finishes. The overall design makes the barstool classic and modern, a perfect choice for residential homes, professional workspaces, cafes and restaurants.

Designed in 1959

Dining chair

Project

Era



EIKUND

[www.eikund.com](http://www.eikund.com)

# Era

## HARDWOOD

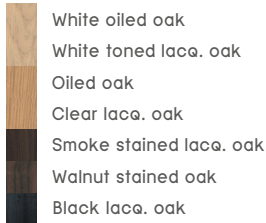

## STEEL FRAME



## SEMI-ANILINE LEATHER RANGE: SPECTRUM

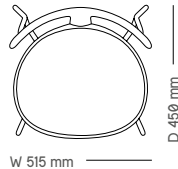
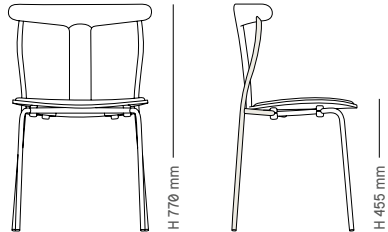
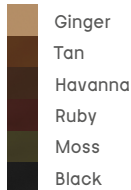

Era is an innovative chair with a modern material mix. It was showcased at the Association of Applied Arts' autumn exhibition in the mid 1950's. Sven Ivar Dyssthe's prototype in steel, wood and leather was honoured in the Norwegian magazine *Bonytt* as the exhibition's most interesting product. Dyssthe graduated from the Royal College of Art in 1954. He designed Era with organic wood and industrial steel, resulting in a versatile chair suited to a range of styles and settings. The black powder coated steel frame, a steam bent T-shaped wooden backrest, together with a light and almost floating veneer seat, provide an elegant design and comfortable form. With its stackable ability it has a perfect combination of aesthetics and pure function. It is now in production for the first time!

Designed in 1956

Dining table - static







Project

Oma





EIKUND

## HARDWOOD FRAME

-  White oiled oak
-  White toned lacq. oak
-  Oiled oak
-  Clear lacq. oak
-  Smoke stained lacq. oak
-  Walnut stained oak
-  Black lacq. oak

## TABLETOP

-  Beige Fenix
-  Teal Fenix
-  Black Fenix

# Oma

Dining table - static

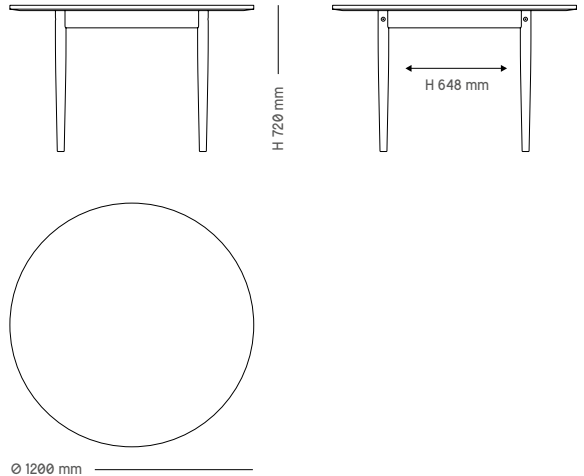

Oma is a dining table that has both a static version and an extendable version.

Oma static is a part of a design series of dining tables designed in the mid 1950s. Sigurd Resell graduated from National Academy of Craft and Art Industry in 1947. He designed Oma while being employed at Rastad & Relling Tegnekontor in Oslo. What characterizes Resell's design is the defined logical construction where form follows function. The tabletop, which comes in solid wood or Fenix laminate, is perfectly balanced with its "sharp" form and modern aesthetics. The framework has a softer organic shape in solid wood, and as a complete product this translates into an instant classic. We are proud to have this beautiful product as part of the Eikund collection.

Designed in 1957.



# Materials

# Hardwood, Fenix & MDF

## Oak

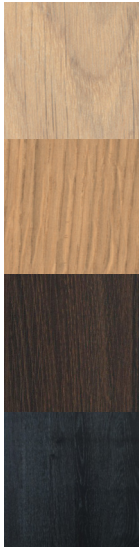

White oil  
White toned lacquer

Oil  
Clear lacquer

Smoke stained  
lacquer

Black lacquer

## Walnut

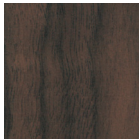

Oil

## Fenix

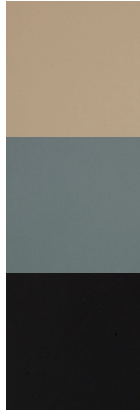

Beige

Teal

Black

## MDF

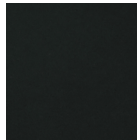

Black lacquer

# Textiles

## Textile group 1



## Textile group 2



## Textile group 3



# Leather

Semi-aniline  
Range: Spectrum



Aniline  
Range: Soft



Aniline  
Range: Saddle



# Rope

## Liros

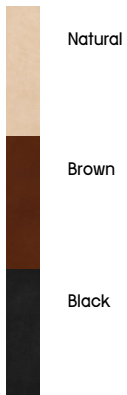

# Sheepskin

## Range: Long



Eikund AS  
Langholmveien 6  
4373 Egersund  
Norway

[www.eikund.com](http://www.eikund.com)  
[post@eikund.com](mailto:post@eikund.com)  
[@eikund\\_norway](#) on Instagram